

# Moovinator CNW Series Filter Receiver

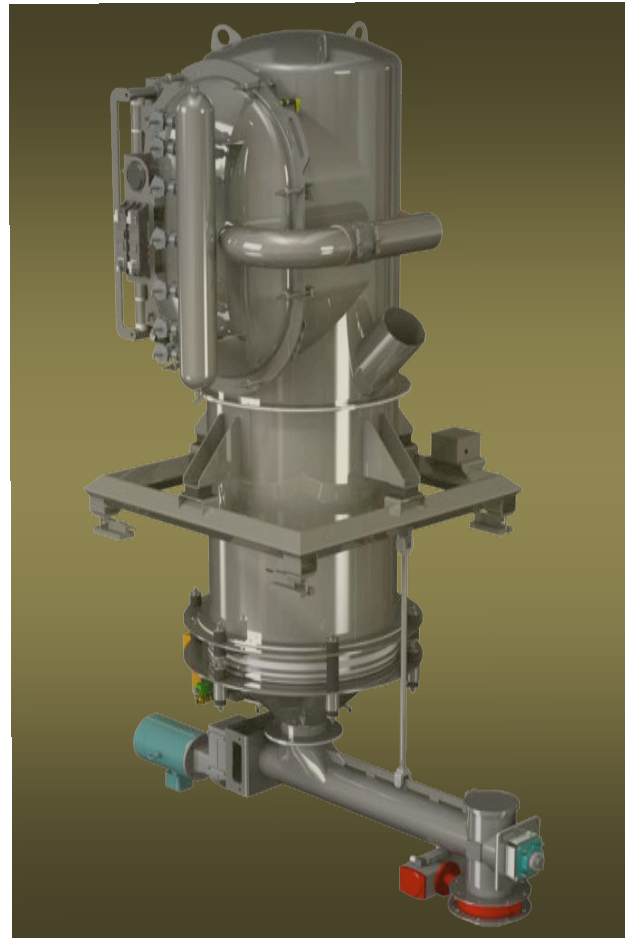

[www.hafequipment.com](http://www.hafequipment.com)

HAF Equipment Inc  
1255 Cope Ave East  
Maplewood MN 55109  
Phone: 651-653-5098

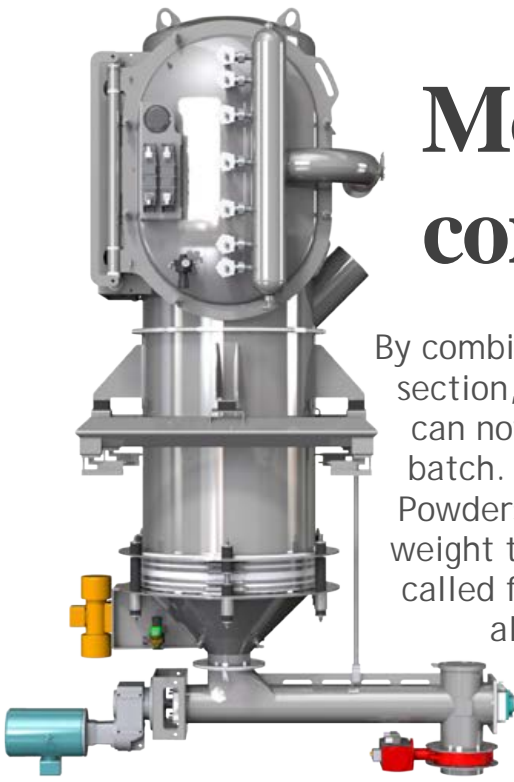

# Moovinator CNW convey and weigh

By combining a Moovinator filter head, a modular surge section, a volumetric tube feeder and a scale, one machine can now convey solids, de-aerate them, and loss in weight batch. Sleek and self contained for big batches or small. Powders are vacuum transferred to CNW module with a weight that is 1.5 times that of batch size. When batch is called for, butterfly valve at feeder opens, feeder starts along with process bin activator for positive discharging. Final scaling is done with CNW in a "quiet" mode for precise L-I-W scaling. Once scaled batch has been made, CNW is ready for a refill.

## Ergonomic

Horizontally loading filter media is easier.

Tool free take apart

No entry required for product zone cleaning

Compact size-about %50 size of conventional filter

Great for low headroom installations

Exclusive velocity arrestor inlet increase convey rates

Size range suitable for 2" dia to 5" dia convey line sizes

## Sizes to match your process rates

Compact size with full size capabilities

Wide range of surge bin sizes

Process bin activator or chisel feeder discharge

Scale sub frame-isolated with four point load cells

Modular constructions suitable for different configurations

Sliding hinge and non sliding hinge options

Filter bags-no cartridges required

Food grade/ USDA-3A dairy/ Chemicals/ Plastics/ Nutraceuticals



[www.hafequipment.com](http://www.hafequipment.com)

HAF Equipment Inc  
1255 Cope Ave East  
Maplewood MN 55109  
Phone: 651-653-5098